

NOZZLE SCHEDULE & ACCESSORIES				
SERVICE	STOCK NO.	SIZE	FITTING	ELEV

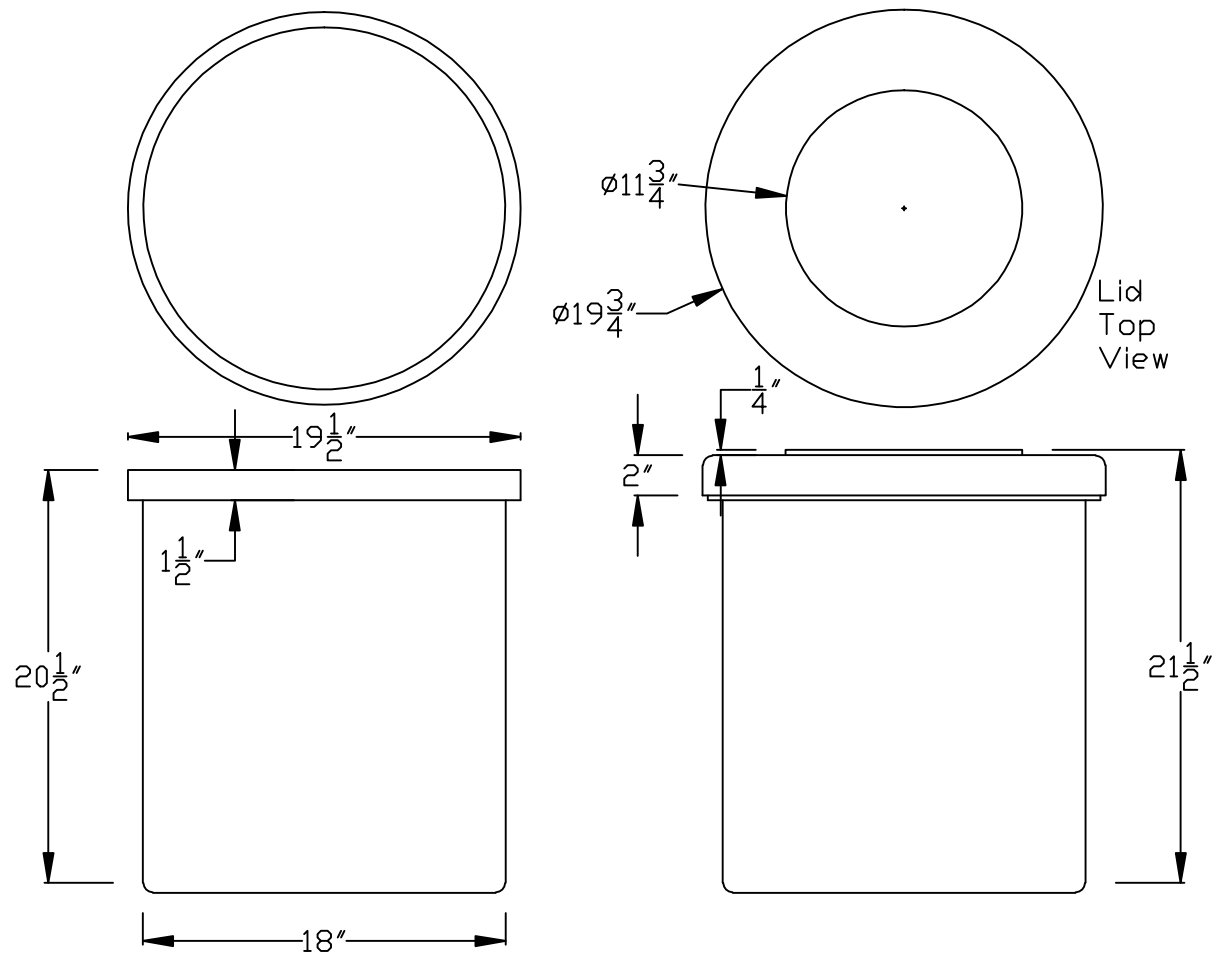

- NOTES**
1. THIS IS A COMPUTER GENERATED DWG. DO NOT REVISE BY HAND.
 2. DIMENSIONS WILL VARY $\pm 3\%$ DUE TO VARIATIONS IN MULTIPLE MOLDS & CONDITIONS PREVALENT DURING MANUFACTURE & USAGE.
 3. MATERIAL OF CONSTRUCTION - HIGH DENSITY POLYETHYLENE
 4. TANK RATING 1.5 SPECIFIC GRAVITY
 5. VOLUME 17 IMPERIAL GALLON

DWG TITLE				
OPEN TOP VERTICAL TANK 17 IMPERIAL GALLONS				
SCALE:	DYNAMIC PLASTIC SOLUTIONS INC.			DR:
DATE: 12/16/11	1-866-559-2357			CK:
PROJECT:	SHEET	COMPUTER FILE	REV	
OT17	1 OF 1	OT17		